

SHOWN: SERVO MOUNT WITH -06 CONNECTOR
 OPTION WITH NO FLAT SEE SHEET TWO AND
 THREE FOR MORE OPTIONS

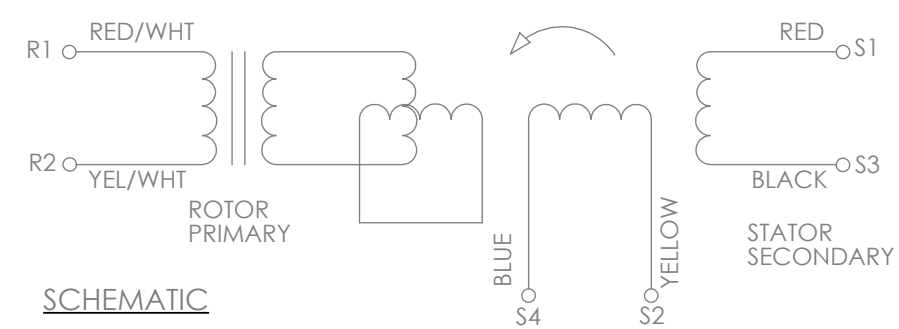
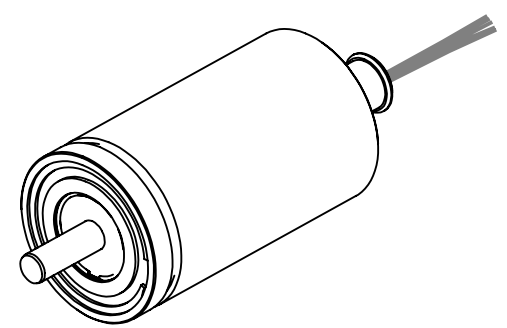

SCHEMATIC

PHASING EQUATION
 FOR CCW ROTATION OF ROTOR FACING
 TRANSFORMER MOUNTING FLANGE END.

$$E(S1-S3) = KE(R1-R2) \cos \theta$$

$$E(S2-S4) = -KE(R1-R2) \sin \theta$$

MECHANICAL DATA		
TEMPERATURE RANGE	°C	- 55 TO + 70
WEIGHT	Max. Kg	0.567
FRICTION TORQUE	Max. N-m	0.04
CONTINUOUS SPEED	RPM	600

**PART, ASSEMBLY, AND ALL COMPONENTS
 MEET EU ROHS DIRECTIVE**

<p>THIRD ANGLE PROJECTION</p>	<p>UNLESS OTHERWISE SPECIFIED: DIMENSIONS ARE IN INCHES DIAMETERS CONCENTRIC .003 TIR FACES PERPENDICULAR -.003 INSIDE CORNERS R .015 MAX</p> <p>INTERPRETATION PER ASME Y14.5M-1994</p>	<p>UNLESS OTHERWISE SPECIFIED: REMOVE ALL BURRS AND BREAK SHARP EDGES -.005/.010</p> <p>TOLERANCES: DECIMAL .00 ±.01 .000 ±.005 ANGLE ±0.5° CHAMFER ANGLE ±10°</p> <p>MACHINE SURFACES 63</p>	<p>PARTS LIST</p>	
			<p>API DELEVAN http://www.delevan.com</p> <p>R15 OUTLINE</p>	
<p>THE INFORMATION CONTAINED IN THIS DRAWING IS THE SOLE PROPERTY OF DELEVAN. ANY REPRODUCTION IN PART OR WHOLE WITHOUT THE WRITTEN PERMISSION OF DELEVAN IS PROHIBITED.</p>	<p>MATERIAL</p> <p>FINISH</p>	<p>APPROVALS</p> <p>CHECKED</p> <p>DES ENG</p>	<p>DATE</p> <p>DATE</p>	<p>SIZE DWG. NO.</p> <p>B</p>
<p>SCALE 3:2</p>		<p>SHEET 1 OF 3</p>		<p>C.CODE IDENT: 99800</p>

PLEASE CONTACT FACTORY FOR OTHER ELECTRICAL AND MECHANICAL OPTIONS

REVISIONS					
REV.	ECO	DESCRIPTION	DATE	APPROVED	CHECKED
-	-	NEW DRAWING			

NUMBERING

R15 - XXXXXX-XXXX

STYLE AND SIZE

MOUNT TYPE	STYLE	CONNECTOR NUMBER	CONNECTOR DETAILS	LEAD EXIT LOCATION	LOCATION	SHAFT FLAT	FLAT STYLE	SHAFT SEAL	SEAL STYLE	WINDING NUMBER	Vrms	KHz	ma Ar ms	Tr	SPEED	ACCURACY NUMBER	±arcmin
S	SERVO MOUNT	06	FLYING LEADS	B	BACK	Y	WITH FLAT .472 [12.0] LENGTH	Y	YES	002	2	10	50	.98	1	S20	20 SPREAD
										004	8	8	50	.50	1	S16	16 SPREAD
	FOR ADDITIONAL STYLES CONTACT THE FACTORY	13	FLYING LEADS WITH SHIELDED CABLE AND DRAIN	T	TOP	N	NO FLAT	N	NO	006	4	5	45	.50	1		
			ADDITIONAL CONNECTORS AND LEAD WIRES AVAILABLE UPON REQUEST		D		DOUBLE FLATS @ 90° .472 [12.0] LENGTH		MORE SHAFT LENGTHS AND STYLES AVAILABLE UPON REQUEST								

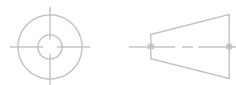
 <p>THIRD ANGLE PROJECTION</p>	<p>UNLESS OTHERWISE SPECIFIED: DIMENSIONS ARE IN INCHES DIAMETERS CONCENTRIC .003 TIR FACES PERPENDICULAR -.003 INSIDE CORNERS R .015 MAX</p> <p>INTERPRETATION PER ASME Y14.5M-1994</p>	<p>UNLESS OTHERWISE SPECIFIED: REMOVE ALL BURRS AND BREAK SHARP EDGES -.005/.010</p> <p>TOLERANCES: DECIMAL .00 ±.01 .000 ±.005 ANGLE ±0.5° CHAMFER ANGLE ±10°</p> <p>MACHINE SURFACES $\sqrt{63}$</p>	PARTS LIST		
			<p>API DELEVAN http://www.delevan.com</p> <p>R15 OUTLINE</p>		
<p>THE INFORMATION CONTAINED IN THIS DRAWING IS THE SOLE PROPERTY OF DELEVAN. ANY REPRODUCTION IN PART OR WHOLE WITHOUT THE WRITTEN PERMISSION OF DELEVAN IS PROHIBITED.</p>		<p>APPROVALS</p> <p>DRAWN -</p> <p>CHECKED -</p> <p>DES ENG -</p>		<p>DATE</p> <p>DATE</p>	
<p>FINISH</p> <p>-</p>		<p>SIZE</p> <p>B</p>		<p>DWG. NO.</p> <p>SCALE - SHEET 2 OF 3 C.CODE IDENT: 99800</p>	

PLEASE CONTACT FACTORY FOR OTHER ELECTRICAL AND MECHANICAL OPTIONS

REVISIONS					
REV.	ECO	DESCRIPTION	DATE	APPROVED	CHECKED
-	-	NEW DRAWING			

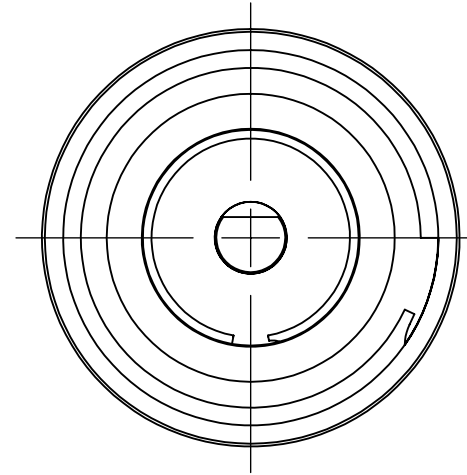
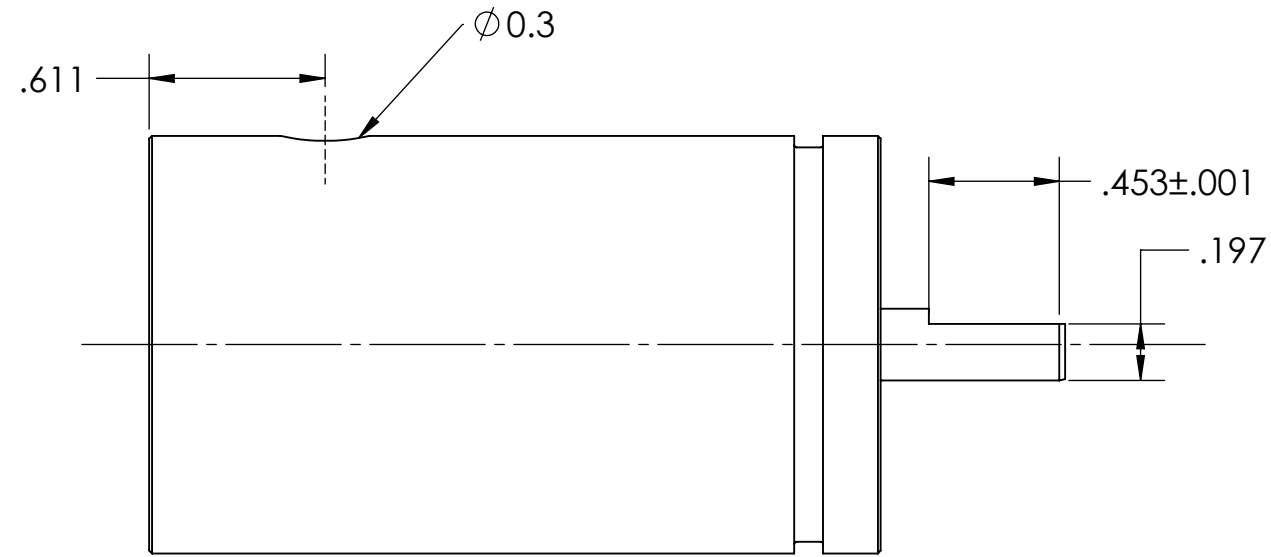

SHOWN: TOP LEAD EXIT WITH SINGLE FLAT

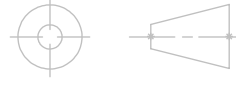
 <p>THIRD ANGLE PROJECTION</p>	<p>UNLESS OTHERWISE SPECIFIED: DIMENSIONS ARE IN INCHES DIAMETERS CONCENTRIC $.003$ TIR FACES PERPENDICULAR $-.003$ INSIDE CORNERS $R .015$ MAX</p> <p>INTERPRETATION PER ASME Y14.5M-1994</p>	<p>UNLESS OTHERWISE SPECIFIED: REMOVE ALL BURRS AND BREAK SHARP EDGES $-.005/.010$</p> <p>TOLERANCES: DECIMAL $.00 \pm .01$ $.000 \pm .005$ ANGLE $\pm 0.5^\circ$ CHAMFER ANGLE $\pm 10^\circ$</p> <p>MACHINE SURFACES $\sqrt{63}$</p>	<p>PARTS LIST</p>		
			<p>API DELEVAN http://www.delevan.com</p> <p>R15 OUTLINE</p>		
<p>THE INFORMATION CONTAINED IN THIS DRAWING IS THE SOLE PROPERTY OF DELEVAN. ANY REPRODUCTION IN PART OR WHOLE WITHOUT THE WRITTEN PERMISSION OF DELEVAN IS PROHIBITED.</p>	<p>MATERIAL</p> <p>-</p>	<p>APPROVALS</p> <p>DRAWN</p> <p>-</p>	<p>DATE</p> <p>-</p>	<p>SIZE</p> <p>B</p>	<p>DWG. NO.</p>
	<p>FINISH</p> <p>-</p>	<p>CHECKED</p> <p>-</p>	<p>DATE</p> <p>-</p>	<p>SCALE</p> <p>-</p>	<p>SHEET 3 OF 3</p>
		<p>DES ENG</p> <p>-</p>	<p>DATE</p> <p>-</p>	<p>C.CODE IDENT: 99800</p>	